

# MICHELANGELO BT A

Automatic barrier for intensive use.

- Range of barriers for intensive use, able to manage useful passages of up to 8 m. The wide range of accessories, incorporated flashing light and the arrangement for installing photocells make them ideal in any context.
- Central control unit with U-Link, programming display and incorporated two-channel radio receiver fitted in the top of the unit for easier access.
- Limit switch system with electronic adjustment that speeds up installation and ensures maximum precision of movement.
- Backup battery power supply system, installable on-board unit.
- IP54 protection rating



U-Link



rolling code



er ready



ee link



24 V



Block

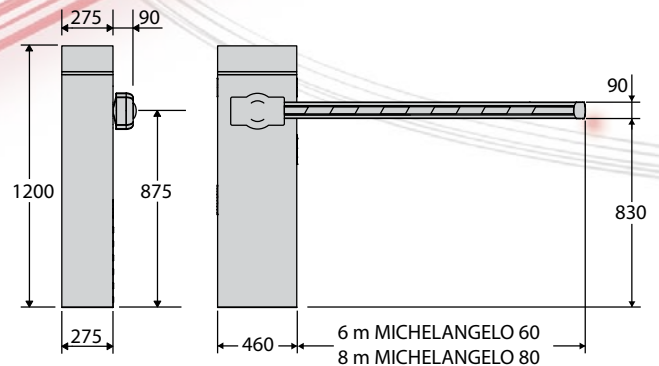
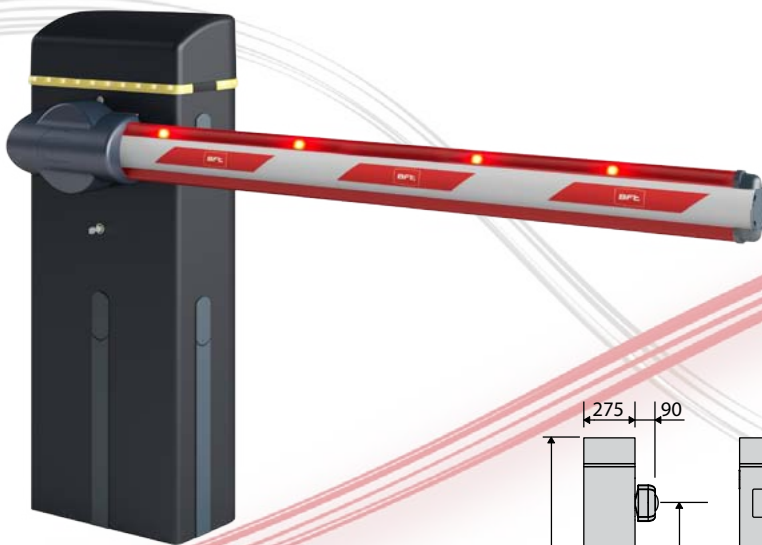

## FEATURES

- Control unit with U-Link and programming display
- IP54 protection
- Management of opposed bars

## SPECIFICATIONS

	MICHELANGELO BT A 60 U	MICHELANGELO BT A 80 U
Useful passage	6 m	8 m
Control unit	MERAK BM	MERAK BM
Power supply	24V	24V
Opening or closing	6 sec.	8 sec.
Type of limit switch	electronic	electronic
Slowdown	adjustable	adjustable
Lock	mechanical	mechanical
Release	key	key
Frequency of use	intensive	intensive
Ambient conditions	from -20 (-40 with thermo activation) °C to 50°C	
Protection rating	IP54	IP54