

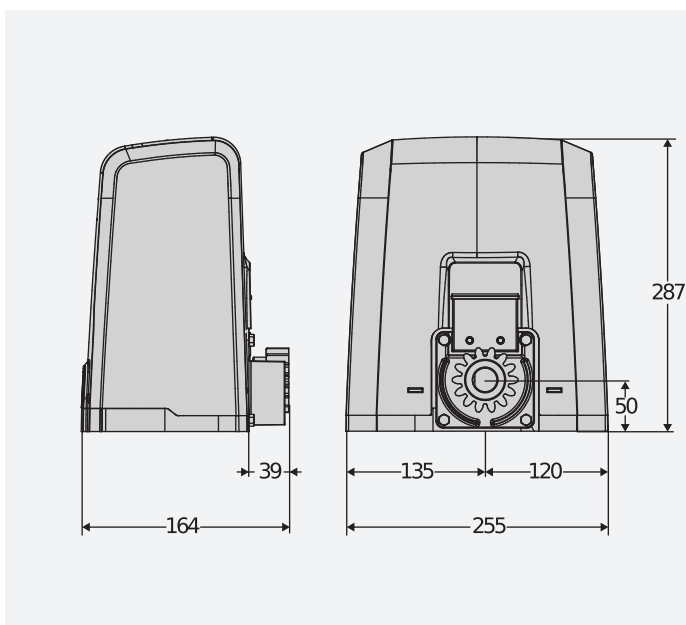

Range of operators for sliding gates weighing up to 600 Kg.
 Power supply 24V.
 Maximum leaf speed up to 16 m/min.
 Residential use.

DIMENSION (MM)



TECHNICAL FEATURES

	DEIMOS BT A600	DEIMOS BT A600 V	DEIMOS BT A600 SQ	DEIMOS BT A600 V SQ	DEIMOS BT A600 120	DEIMOS BT A600 V 120
Control unit						
Board power supply	230 V	230 V	230 V	230 V	120 V	120 V
Supply voltage AC	24 V	24 V	24 V	24 V	120 V	120 V
Power input	70 W	70 W	70 W	70 W	70 W	70 W
Max. door/gate weight	600 kg	360 kg	600 kg	360 kg	600 kg	360 kg
Gate speed	12 m/min	16 m/min	12 m/min	16 m/min	12 m/min	16 m/min
Type of limit switch	Electromechanical	Electromechanical	Electromechanical	Electromechanical	Electromechanical	Electromechanical
Pinion module	4	4	4	4	4	4
Slowdown	Yes	Yes	Yes	Yes	Yes	Yes
Locking	Mechanical	Mechanical	Mechanical	Mechanical	Mechanical	Mechanical
Release	Lever-operated with personal key	Lever-operated with personal key	Lever-operated with personal key	Lever-operated with personal key	Lever-operated with personal key	Lever-operated with personal key
Impact reaction	D-Track	D-Track	D-Track	D-Track	D-Track	D-Track
Frequency of use	intensive	intensive	intensive	intensive	intensive	intensive
Protection rating	IP24					
Environmental conditions	-20 ÷ 55 °C					

		Description
P925222 00002	DEIMOS BT A400	Operator 24 V for sliding gates up to 400 kg in weight. Leaf speed 12 m/min. Limit switch Electromechanical.
P925222 00003	DEIMOS BT A400 V	Operator 24 V for sliding gates up to 300 kg in weight. Leaf speed 16 m/min. Limit switch Electromechanical.
P925222 00005	DEIMOS BT A400 SQ	Operator 24 V for sliding gates up to 400 kg in weight. Leaf speed 12 m/min. Limit switch Electromechanical.
P925222 00006	DEIMOS BT A400 V SQ	Operator 24 V for sliding gates up to 300 kg in weight. Leaf speed 16 m/min. Limit switch Electromechanical.
P925222 00001	DEIMOS BT A400 120	Operator 120 V for sliding gates up to 400 kg in weight. Leaf speed 12 m/min. Limit switch Electromechanical.
P925222 00004	DEIMOS BT A400 V 120	Operator 120 V for sliding gates up to 300 kg in weight. Leaf speed 16 m/min. Limit switch Electromechanical.
P925224 00002	DEIMOS BT A600	Operator 24 V for sliding gates up to 600 kg in weight. Leaf speed 12 m/min. Limit switch Electromechanical.
P925224 00003	DEIMOS BT A600 V	Operator 24 V for sliding gates up to 360 kg in weight. Leaf speed 16 m/min. Limit switch Electromechanical.
P925224 00005	DEIMOS BT A600 SQ	Operator 24 V for sliding gates up to 600 kg in weight. Leaf speed 12 m/min. Limit switch Electromechanical.
P925224 00006	DEIMOS BT A600 V SQ	Operator 24 V for sliding gates up to 360 kg in weight. Leaf speed 16 m/min. Limit switch Electromechanical.
P925224 00001	DEIMOS BT A600 120	Operator 120 V for sliding gates up to 600 kg in weight. Leaf speed 12 m/min. Limit switch Electromechanical.
P925224 00004	DEIMOS BT A600 V 120	Operator 120 V for sliding gates up to 360 kg in weight. Leaf speed 16 m/min. Limit switch Electromechanical.
R925267 00002	DEIMOS BT KIT A400 FRA	Complete kit 24 V for sliding gates weighing up to 400 kg. Leaf speed 12 m/min. Limit switch Electromechanical.
R925271 00002	DEIMOS BT KIT A600 FRA	Complete kit 24 V for sliding gates weighing up to 600 kg. Leaf speed 12 m/min. Limit switch Electromechanical.

HAMAL: Control panel with trimmer and dip switch for one operator, 230V - 70W.

C-U-HAMAL - HAMAL - Built-In



- Control panel with trimmer and dip switch for one operator, 230V - 70W
- Application: built-in control unit for one 24V operator for sliding gates
- Board power supply: 230V single-phase
- Operator power supply: 24V 80W
- Main features: removable terminal blocks with new standard colour-coding, dip-switch programming and potentiometers, incorporated dual channel receiver, D-Track anti-crushing system, slowdown during opening and closing
- Main functions: automatic re-closing, pedestrian opening, input for 8k2 edge, fast closing

RECOMMENDED ACCESSORIES

	D221073 - CP		N999320 - CVZ-S
	plastic rack, 4-module, cross-section 22 x 22 mm, length 1 m, screw-fitted into slots. Max. load capacity 600 kg.		steel rack, 4-module, cross-section 30 x 8 mm, length 1 m, screw-fitted on supports. Max. load capacity 800 kg.
	N999151 - SFD		P125035 - SL BAT2
	Base plate for DEIMOS series (supplied with operator).		Emergency battery kit for Deimos BT A, Ares BT A, Deimos Ultra BT A, Ares Ultra BT A.