



-  24 V
-  ee link
-  er ready
-  d-track



Range of 24V sliding gate operators for intensive use with leaves up to 1500 kg, maximum leaf speed 12 m/min

DIMENSION (MM)

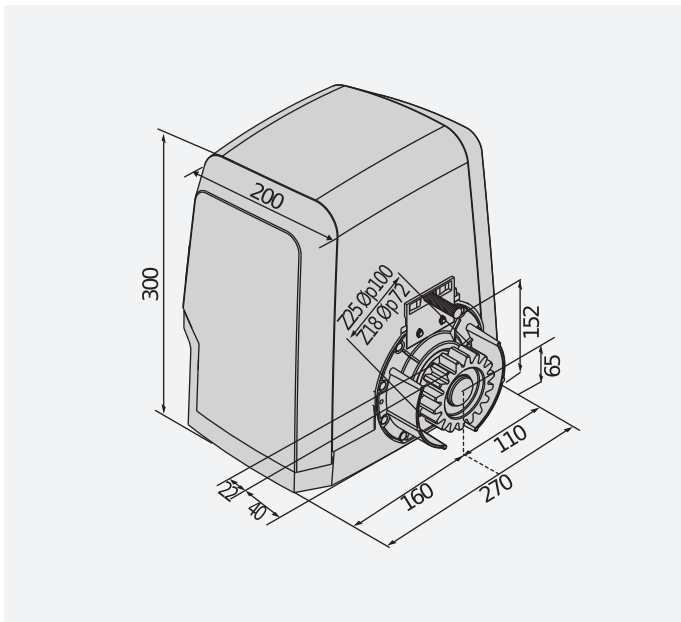

TECHNICAL FEATURES

	ARES BT A1000 V	ARES BT A1500 V	ARES BT A1000	ARES BT A1500
Control unit	HAMAL			
Board power supply	230 V	230 V	230 V	230 V
Supply voltage AC	24 V	24 V	24 V	24 V
Power input	240 W	400 W	240 W	400 W
Max. door/gate weight	500 kg	750 kg	1000 kg	1500 kg
Gate speed	12 m/min	12 m/min	9 m/min	9 m/min
Type of limit switch	Electromechanical	Electromechanical	Electromechanical	Electromechanical
Pinion module	4	4	4	4
Slowdown	Yes	Yes	Yes	Yes
Locking	Mechanical	Mechanical	Mechanical	Mechanical
Release	Knob operated with personal key	Knob operated with personal key	Knob operated with personal key	Knob operated with personal key
Impact reaction	D-Track	D-Track	D-Track	D-Track
Frequency of use	intensive	intensive	intensive	intensive
Protection rating	IP24			
Environmental conditions	-20 ÷ 55 °C			

		Description
P926190 00002	ARES BT A1000 V	Operator 24 V for sliding gates up to 500 kg in weight. Leaf speed 12 m/min. Limit switch Electromechanical.
P926188 00002	ARES BT A1500 V	Operator 24 V for sliding gates up to 750 kg in weight. Leaf speed 12 m/min. Limit switch Electromechanical.
P926189 00002	ARES BT A1000	Operator 24 V for sliding gates up to 1000 kg in weight. Leaf speed 9 m/min. Limit switch Electromechanical.
P926187 00002	ARES BT A1500	Operator 24 V for sliding gates up to 1500 kg in weight. Leaf speed 9 m/min. Limit switch Electromechanical.

HAMAL: Control panel with trimmer and dip switch for one operator, 230V - 70W.

C-U-HAMAL - HAMAL - Built-In



- Control panel with trimmer and dip switch for one operator, 230V - 70W
- Application: built-in control unit for one 24V operator for sliding gates
- Board power supply: 230V single-phase
- Operator power supply: 24V 80W
- Main features: removable terminal blocks with new standard colour-coding, dip-switch programming and potentiometers, incorporated dual channel receiver, D-Track anti-crushing system, slowdown during opening and closing
- Main functions: automatic re-closing, pedestrian opening, input for 8k2 edge, fast closing

RECOMMENDED ACCESSORIES

	D221073 - CP plastic rack, 4-module, cross-section 22 x 22 mm, length 1 m, screw-fitted into slots. Max. load capacity 600 kg.		N999320 - CVZ-S steel rack, 4-module, cross-section 30 x 8 mm, length 1 m, screw-fitted on supports. Max. load capacity 800 kg.
	D571053 - CVZ steel rack, 4-module, cross-section 30 x 12 mm, length 1 m, screw-fitted on supports. Max. load capacity 1000 kg.		D571054 - CFZ galvanized steel rack, 4-module, cross-section 22 x 22 mm, length 2 m, welding. Max. load capacity 2000 kg.
	N999156 - SFI Base plate for ARES and ICARO (supplied with operator).		P125035 - SL BAT2 Emergency battery kit for Deimos BT A, Ares BT A, Deimos Ultra BT A, Ares Ultra BT A.
	P125018 - THEKE B PRA 01 Metal protection box for ARES and ICARO series sliding operators.		

